

ASSEMBLY INSTRUCTIONS (HP)

MODEL NO. 292 "HEIRLOOM CHERRY"

296 "NOSTALGIC OAK"

PARTS

- (A) ARMOIRE
- (B) LEGS (4)
- (C) MACHINE SCREWS (8)
- (D) WASHERS (8)
- (E) WOOD SCREWS (4)
- (F) TOP
- (G) FOAM PADS (2)

HARDWARE ILLUSTRATION

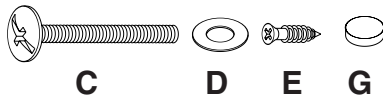

Tools required: Screwdriver (not included)

ATTENTION: SOME NUMBERED PARTS LISTED ON THE INSTRUCTION SHEET MAY NOT BE IN PARTS BAG AS THEY MAY ALREADY BE ASSEMBLED. CAREFULLY CHECK PARTS AND PACKING MATERIALS PRIOR TO ORDERING REPLACEMENTS.

Thank you for purchasing this quality product. Be sure to check all packing material carefully for small parts which may have come loose inside the carton during shipment. Separate, identify, and count all parts and metal hardware. Compare with parts list to be sure all parts are present. If any part(s) are missing or damaged, phone, fax, or mail to our Customer Service Department. For efficient and speedy service, please indicate the model number and code letter of part(s) needed.

Note; Legs may be packed in separate carton within armoire.
Note; Hardware bag is located in bottom drawer

IMPORTANT NOTE: Follow instructions listed below in the proper sequence as numbered to assure fast, easy and correct assembly.

1. **Note:** Upon opening, thoroughly clean all wood surfaces with furniture polish to remove dust and dirt that may have settled onto finish during shipment.
2. Carefully Place Armoire (A) upside down on a soft cloth. Insert Machine Screws (C) through Washers (D), through skirt of Armoire (A) and tighten into Legs (B). (See ill. #1)
3. Stand Armoire (A) upright. Insert Wood Screws (E) through hinge attached to Armoire (A) and tighten into edge of Top (F). Remove paper backing from Foam Pads (G) and place onto corners of Armoire (A). (See ill. #2 & #3)
4. Your furniture has been handcrafted and skillfully finished by fine craftsmen. Rich, deep antique finishes have been applied which require very little polish. However, should you desire a shinier finish, simply use any good grade of furniture polish, rubbing the finish lightly as it is being applied. Allow to dry and buff lightly with a soft cloth.

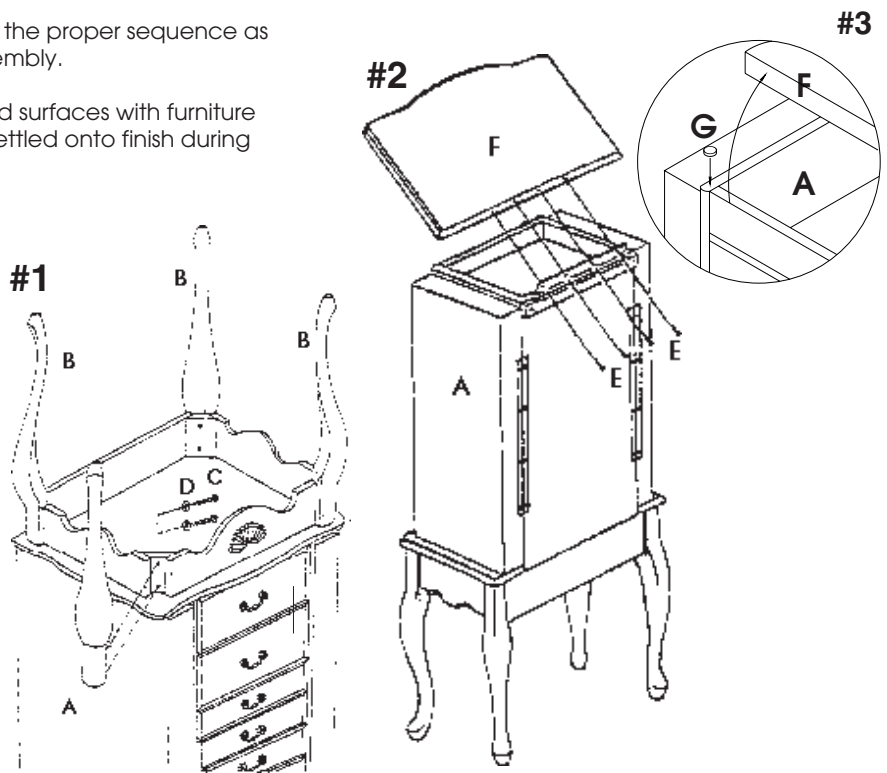

IF YOU HAVE A PROBLEM, WE WANT TO HAVE THE OPPORTUNITY TO MAKE IT RIGHT!

Should there be any missing or defective part(s),

FAX this form to (310) 841-0842

or call Customer Service at (310) 204-2224

Have your model number and part code letter handy.

MODEL NO. 292 "HEIRLOOM CHERRY"
296 "NOSTALGIC OAK"

© 1996 Powell

Part Letter	Description	Quantity

Name _____
 Address _____
 Daytime Phone () _____
 Reason for Replacement _____
 Place of Purchase _____